

KOMATSU

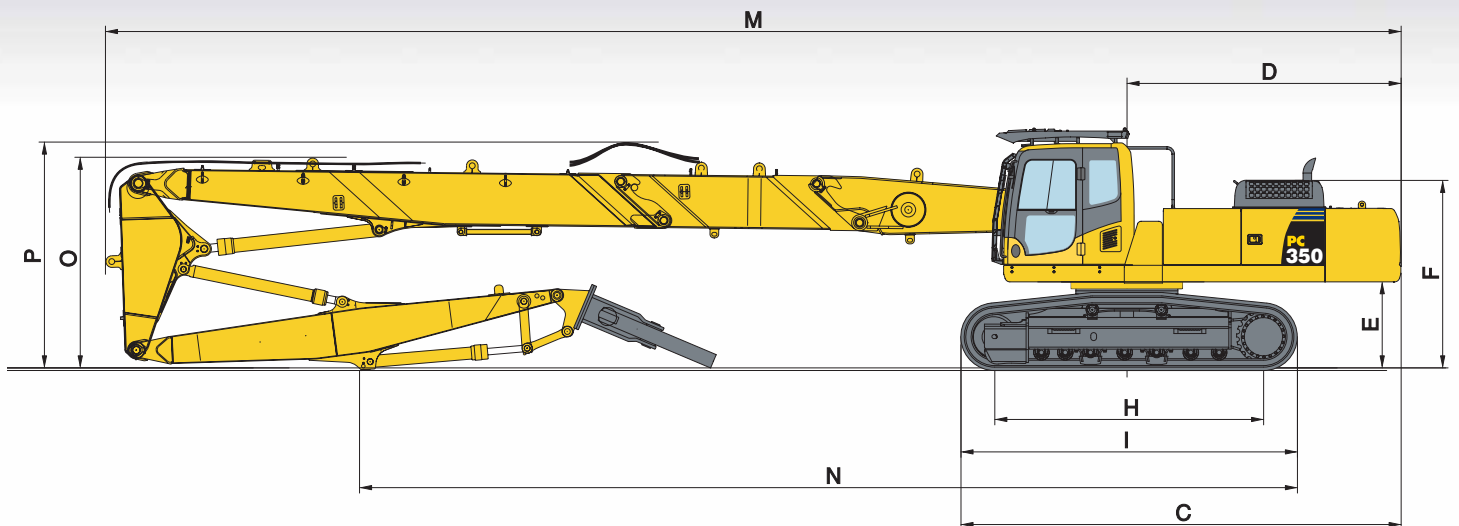

Hydraulic Excavator

PC350LC/NLC-8

High Reach Demolition Specification

ENGINE POWER

194 kW / 260 HP @ 1.950 rpm

OPERATING WEIGHT

PC350LC-8: 38.895 - 48.190 kg

PC350NLC-8: 38.785 - 54.195 kg

ATTACHMENT TOOL WEIGHT

max. 2.500 kg

Specifications

ENGINE

Model	Komatsu SAA6D114E-3
Type	Common rail direct injection, water-cooled, emissionised, turbocharged, after-cooled diesel
Engine power	
at rated engine speed	1.950 rpm
ISO 14396	194 kW / 260 HP
ISO 9249 (net engine power)	184 kW / 247 HP
No. of cylinders	6
Bore × stroke	114 × 135 mm
Displacement	8,27 ltr
Battery	2 × 12 V/140 Ah
Alternator	24 V/60 A
Starter motor	24 V/11 kW
Air filter type	Double element type with monitor panel dust indicator and auto dust evacuator
Cooling	Suction type cooling fan with radiator fly screen

HYDRAULIC SYSTEM

Type	HydrauMind. Closed-centre system with load sensing and pressure compensation valves
Additional circuits	2 additional circuits are installed
Main pump	2 variable displacement piston pumps supplying boom, arm, bucket, swing and travel circuits
Maximum pump flow	2 × 268 ltr/min
Relief valve settings	
Implement	380 bar
Travel	380 bar
Swing	285 bar
Pilot circuit	33 bar

UNDERCARRIAGE

Construction	X-frame centre section with box section track-frames
Track assembly	
Type	Fully sealed
Shoes (each side)	48 (LC/NLC); 49 (HWG)
Tension	Combined spring and hydraulic unit
Rollers	
Track rollers (each side)	8 (LC/NLC); 10 (HWG)
Carrier rollers (each side)	2

OPERATING WEIGHT (APPR.)

	HIGH REACH				MEDIUM REACH				EXCAVATION BOOM			
	PC350LC-8		PC350NLC-8		PC350LC-8		PC350NLC-8		PC350LC-8		PC350NLC-8	
Triple grouser shoes	Operating weight	Ground pressure	Operating weight	Ground pressure	Operating weight	Ground pressure	Operating weight	Ground pressure	Operating weight	Ground pressure	Operating weight	Ground pressure
600 mm	47.810 kg	0,91 kg/cm ²	47.700 kg	0,91 kg/cm ²	46.550 kg	0,89 kg/cm ²	46.440 kg	0,88 kg/cm ²	38.651 kg	0,74 kg/cm ²	38.541 kg	0,74 kg/cm ²
700 mm	48.190 kg	0,78 kg/cm ²	48.080 kg	0,78 kg/cm ²	46.930 kg	0,77 kg/cm ²	46.820 kg	0,77 kg/cm ²	39.031 kg	0,64 kg/cm ²	39.141 kg	0,64 kg/cm ²

Operating weight, including specified work equipment. High reach and medium reach includes attachment weight of 2.500 kg. Excavation boom equipment includes 3,2 m arm and 1.290 kg bucket. All include operator, lubricant, coolant, full fuel tank. Optional Hydraulic Wide Gauge (HWG) undercarriage adds approx. 6.115 kg to the machine weight (compared with NLC undercarriage).

SWING SYSTEM

Type	Axial piston motor driving through planetary double reduction gearbox
Swing lock	Electrically actuated wet multi-disc brake integrated into swing motor
Swing speed	0 - 9,5 rpm
Swing torque	102,9 kNm

DRIVES AND BRAKES

Steering control	2 levers with pedals giving full independent control of each track
Drive method	Hydrostatic
Travel operation	Automatic 3-speed selection
Max. travel speeds	
Lo / Mi / Hi	3,2 / 4,5 / 5,5 km/h
Maximum drawbar pull	26.900 kg
Brake system	Hydraulically operated discs in each travel motor

SERVICE REFILL CAPACITIES

Fuel tank	605 ltr
Radiator	32 ltr
Engine oil	35 ltr
Swing drive	16,5 ltr
Hydraulic tank	188 ltr
Final drive (each side)	9 ltr

ENVIRONMENT

Engine emissions	Fully complies with EU Stage IIIA exhaust emission regulations
Noise levels	
LwA external	105 dB(A) (2000/14/EC Stage II)
LpA operator ear	71 dB(A) (ISO 6396 dynamic test)
Vibration levels (EN 12096:1997)*	
Hand/arm	≤ 2,5 m/s ² (uncertainty K = 0,22 m/s ²)
Body	≤ 0,5 m/s ² (uncertainty K = 0,12 m/s ²)

* for the purpose of risk assessment under directive 2002/44/EC, please refer to ISO/TR 25398:2006.

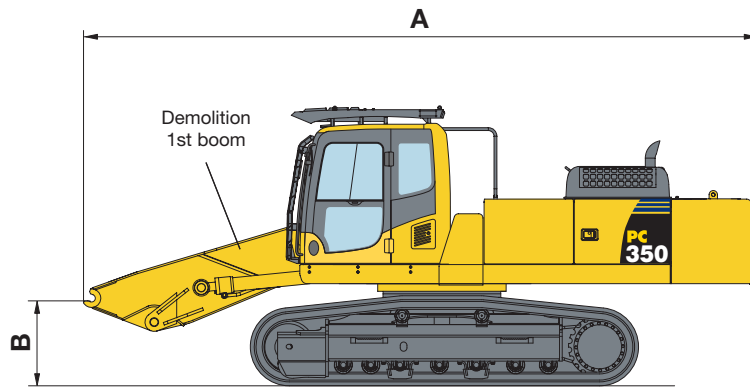

MACHINE DIMENSIONS

A	Transport length	8.060 mm
B	Maximum boom height (incl. hydraulic lines)	1.500 mm
	Transport weight with LC undercarriage (700 mm shoes, not including additional counterweight)	33.400 kg
	Additional weight for hydraulic wide gauge	6.115 kg
	Additional counterweight (1.470 mm × 730 mm × 535 mm)	4.490 kg

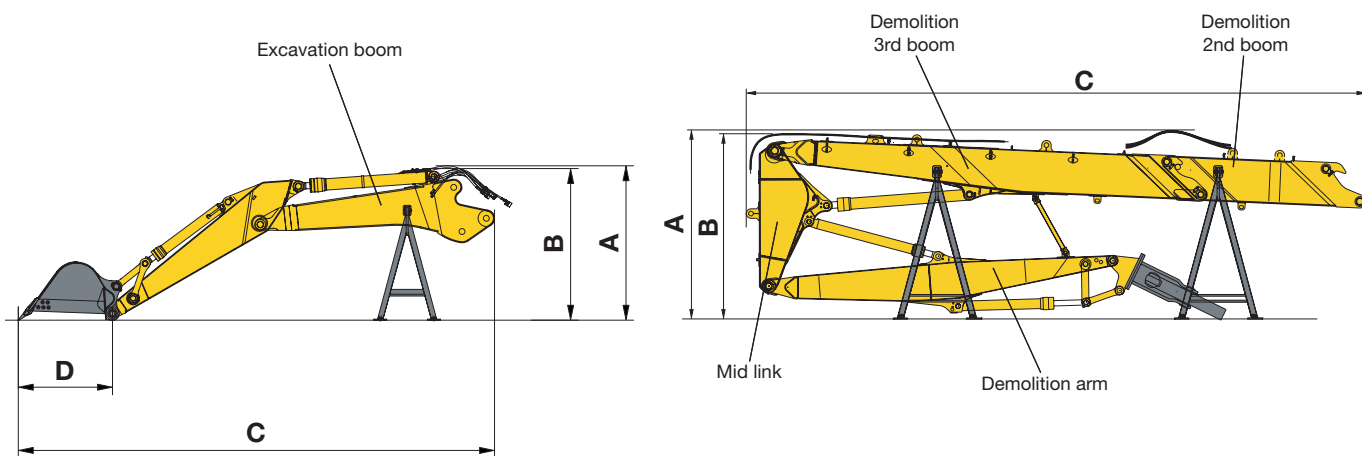

EQUIPMENT	EXCAVATION BOOM	HIGH REACH BOOM		
	2,6 m arm	3,2 m arm		
A	Total height (incl. hydraulic lines)	2.625 mm	2.600 mm	3.205 mm
B	Height	2.540 mm	2.515 mm	3.140 mm
C	Length	8.110 mm	8.900 mm	10.515 mm
D	Tip radius	1.675 mm	1.675 mm	–
	Support weight	304 kg	304 kg	755 kg
	2nd boom weight	2.490 kg	2.490 kg	1.270 kg
	3rd boom weight 1)	–	–	2.500 kg
	Mid link weight	–	–	810 kg
	Arm weight 1)	1.710 kg	1.850 kg	1.790 kg
	Bucket weight	1.290 kg	1.290 kg	–
	Total weight 2)	6.040 kg	6.180 kg	8.555 kg

1) Not including hydraulic cylinder.

2) Including hydraulic cylinders, links, hydraulic lines, stands and stated attachment weight.

Transport Dimensions

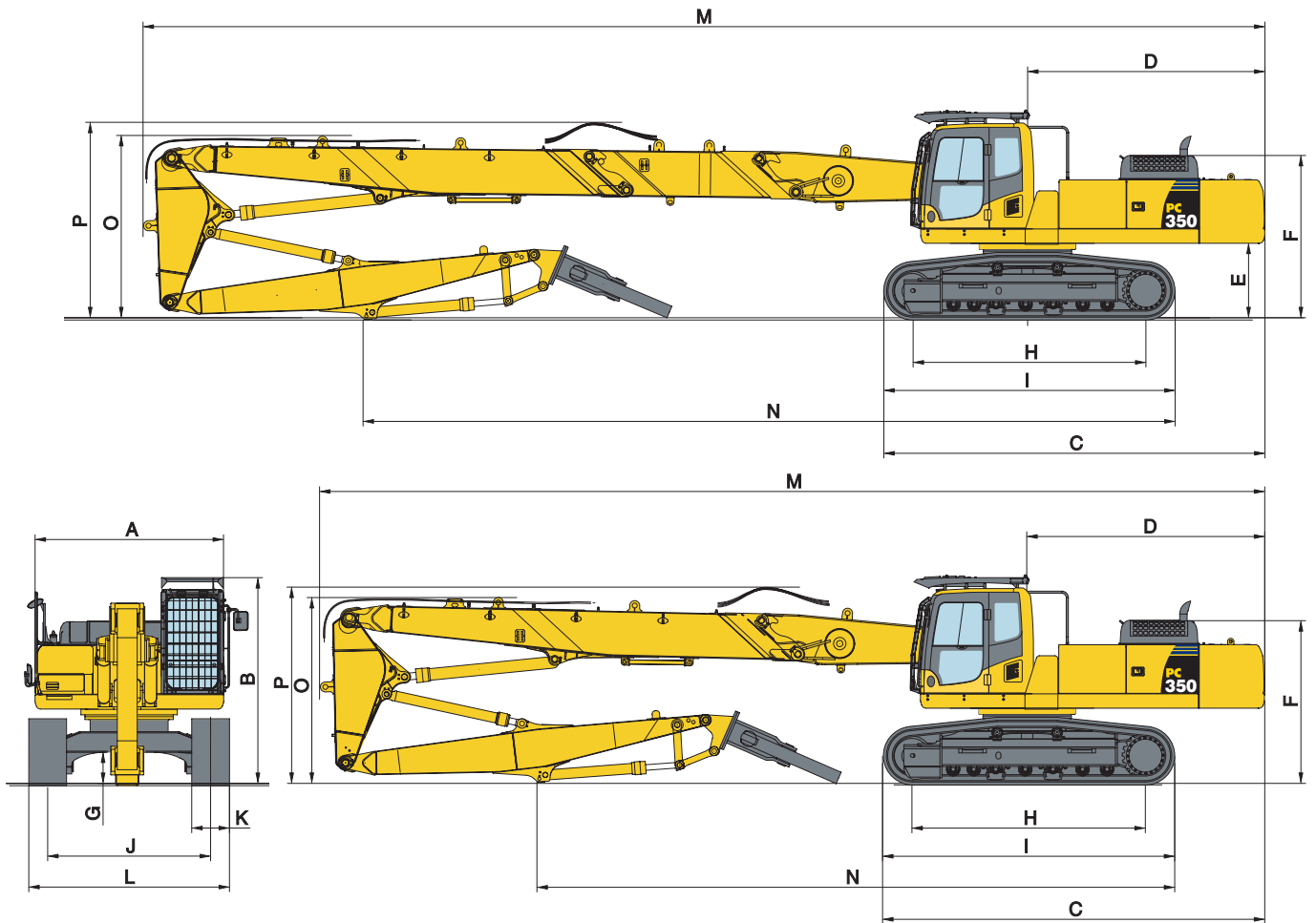

MACHINE DIMENSIONS	HIGH REACH	MEDIUM REACH
A Overall width of upper structure ¹⁾	2.995 mm	2.995 mm
B Overall height of cab, with FOPS ²⁾	3.305 mm	3.305 mm
Overall height of cab, without FOPS ²⁾	3.100 mm	3.100 mm
C Overall length of basic machine	6.250 mm	6.250 mm
D Tail length	3.775 mm	3.775 mm
E Clearance under counterweight	1.185 mm	1.185 mm
F Machine tail height	2.585 mm	2.585 mm
G Ground clearance	498 mm	498 mm
Ground clearance (HWG undercarriage)	449 mm	449 mm
H Tumbler centre distance	4.030 mm	4.030 mm
I Track length	4.955 mm	4.955 mm
J Track gauge	2.590 mm (2.390 mm)	2.590 mm (2.390 mm)
Track gauge (HWG undercarriage)	2.280 - 3.180 mm	2.280 mm - 3.180 mm
K Track shoe width (700 mm only for HWG undercarriage)	600 mm, 700 mm	600 mm, 700 mm
L Overall track width with 600 mm shoes ³⁾	3.190 mm (2.990 mm)	3.190 mm (2.990 mm)
Overall track width with 700 mm shoes ³⁾	3.290 mm (3.090 mm)	3.290 mm (3.090 mm)
Overall track width with 700 mm shoes (HWG undercarriage)	2.980 mm - 3.880 mm	2.980 mm - 3.880 mm
M Transport length	17.800 mm	15.150 mm
N Length on ground (transport)	16.100 mm	13.450 mm
O Overall height (to top of boom)	2.880 mm	2.950 mm
P Overall height (to top of hose)	3.150 mm	3.150 mm

1) Overall width of upper structure excludes side guards, handrails and mirrors. Side guards can be removed if transport width of less than 3 m is required.

2) Overall height with Hydraulic Wide Gauge (HWG) undercarriage: + 105 mm

3) NLC figures in brackets ()

EXCAVATION BOOM - BENT POSITION

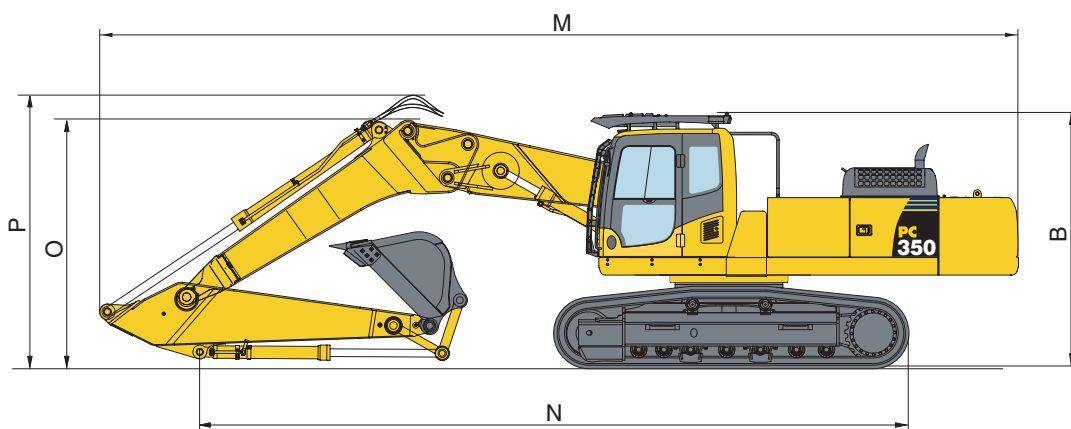

ARM LENGTH	2,6 m	3,2 m
M Overall transport length	12.045 mm	11.955 mm
N Transport length	6.930 mm	9.220 mm
B Transport height (to top of cab, with FOPS)	3.305 mm	3.305 mm
Transport height (to top of cab, without FOPS)	3.085 mm	3.085 mm
O Transport height (to top of boom)	3.420 mm	3.225 mm
P Transport height (to top of hose)	3.740 mm	3.550 mm

Overall height with Hydraulic Wide Gauge (HWG) undercarriage: + 105 mm

EXCAVATION BOOM - STRAIGHT POSITION

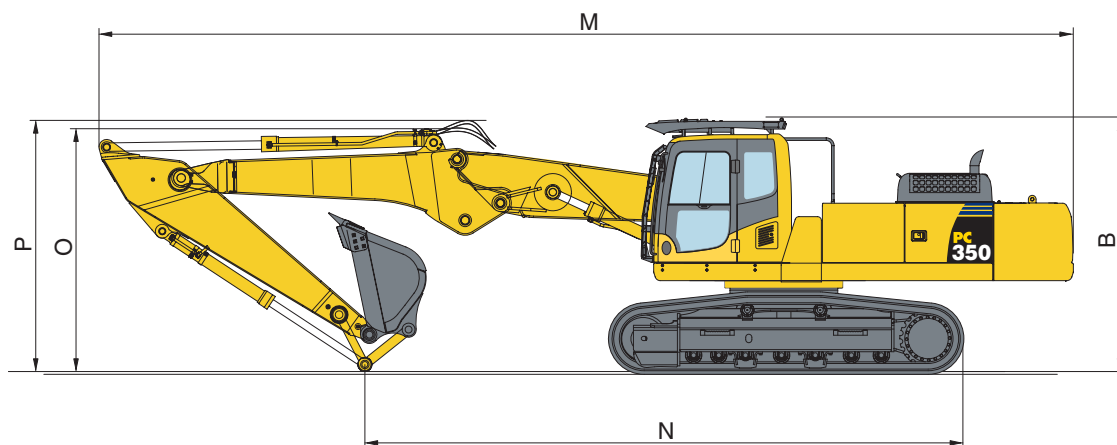

ARM LENGTH	2,6 m	3,2 m
M Overall transport length	12.760 mm	12.670 mm
N Transport length	8.520 mm	7.780 mm
B Transport height (to top of cab, with FOPS)	3.305 mm	3.305 mm
Transport height (to top of cab, without FOPS)	3.085 mm	3.085 mm
O Transport height (to top of boom)	3.050 mm	3.165 mm
P Transport height (to top of hose)	3.300 mm	3.400 mm

Overall height with Hydraulic Wide Gauge (HWG) undercarriage: + 105 mm

Working Range

HIGH REACH DEMOLITION

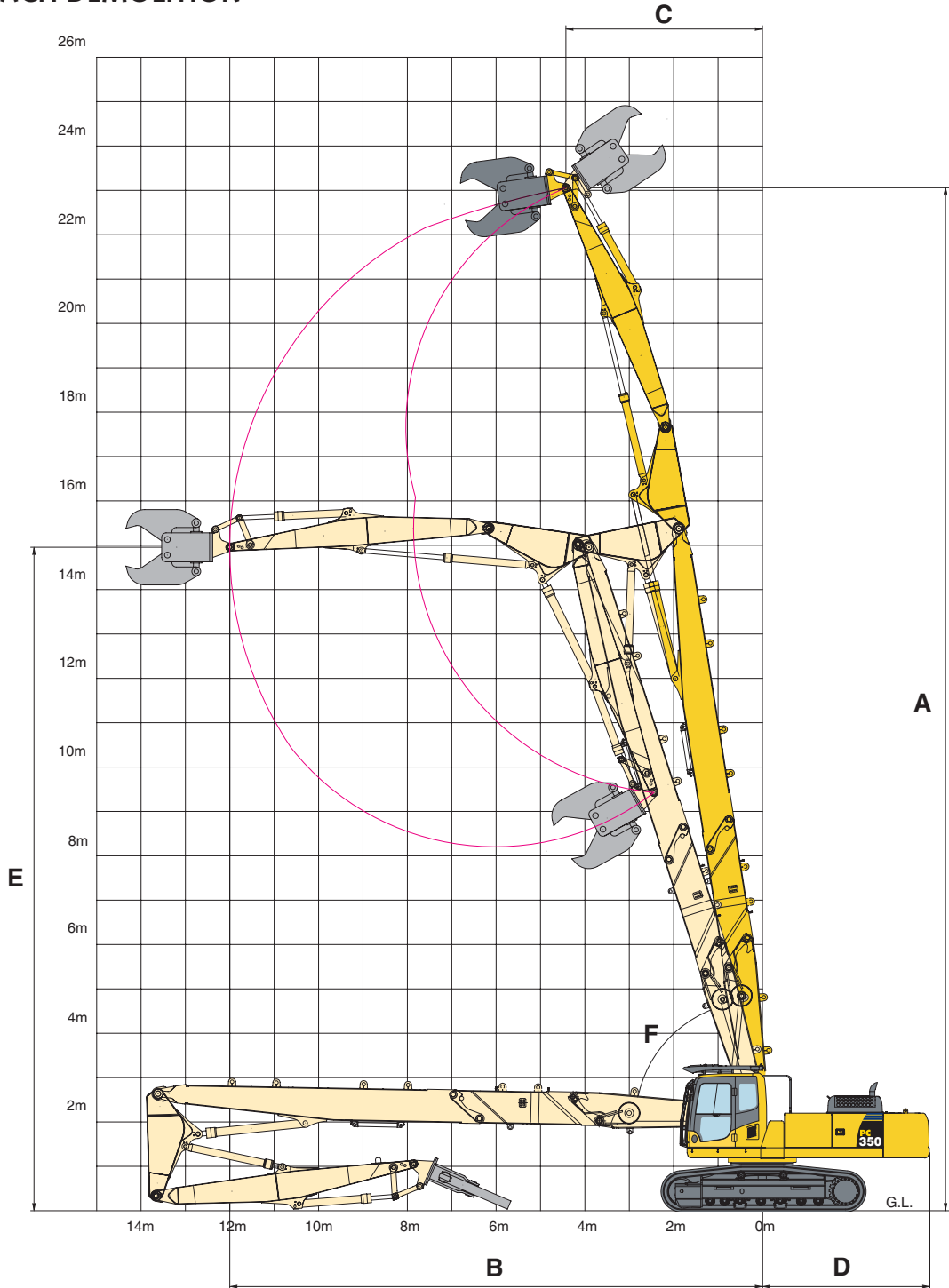

HIGH REACH DEMOLITION

A	Max. working height (to pin at arm end)	23.060 mm
B	Max. forward reach	12.000 mm
C	Min. swing radius of arm end pin (max. height)	4.430 mm
D	Tail swing radius	3.820 mm
E	Height at max. reach	14.955 mm
F	Min. boom angle from ground at max. height	75°

This working range is applicable through 360 degrees (depending upon fitted attachment) (for LC or HWG undercarriage). For operator and jobsite safety, Komatsu recommend that high reach demolition machines work in line with the trackframe wherever possible.

MEDIUM REACH DEMOLITION

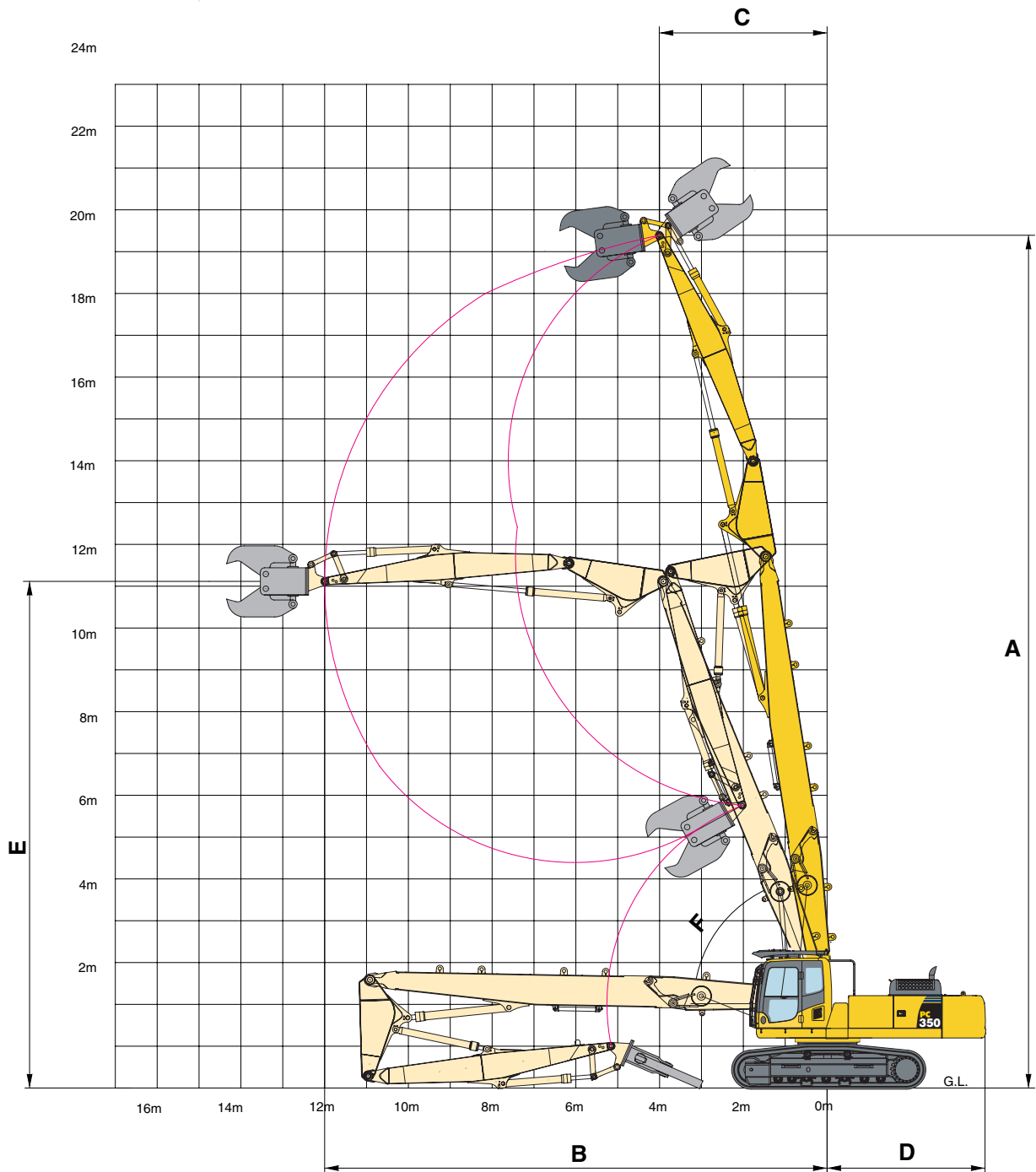

MEDIUM REACH DEMOLITION

A	Max. working height (to pin at arm end)	20.390 mm
B	Max. forward reach	12.000 mm
C	Min. swing radius of arm end pin (max. height)	4.010 mm
D	Tail swing radius	3.820 mm
E	Height at max. reach	11.950 mm
F	Min. boom angle from ground at max. height	70°

This working range is applicable through 360 degrees (depending upon fitted attachment) (for LC or HWG undercarriage). For operator and jobsite safety, Komatsu recommend that high reach demolition machines work in line with the trackframe wherever possible.

Working Range

EXCAVATION BOOM - BENT POSITION

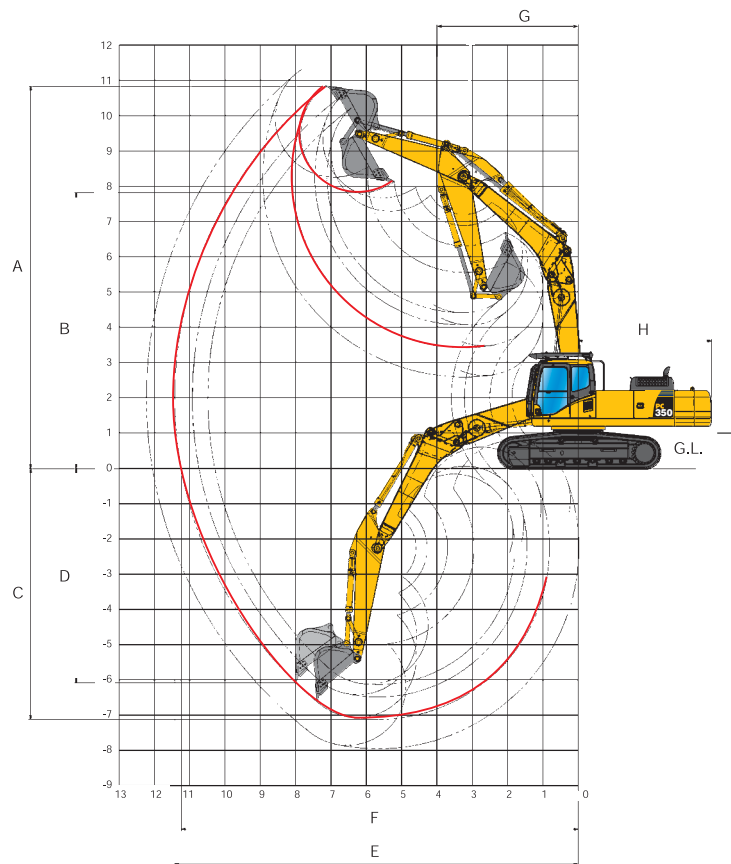

ARM LENGTH	2,6 m	3,2 m
A Max. digging height	10.730 mm	10.845 mm
B Max. dumping height	7.665 mm	7.810 mm
C Max. digging depth	6.485 mm	7.120 mm
D Max. vertical wall digging depth	5.675 mm	6.075 mm
E Max. digging reach	10.925 mm	11.425 mm
F Max. digging reach at ground level	10.735 mm	11.245 mm
G Min. swing radius (bucket loaded)	4.095 mm	3.970 mm
H Tail swing radius	3.820 mm	3.820 mm



EXCAVATION BOOM - STRAIGHT POSITION

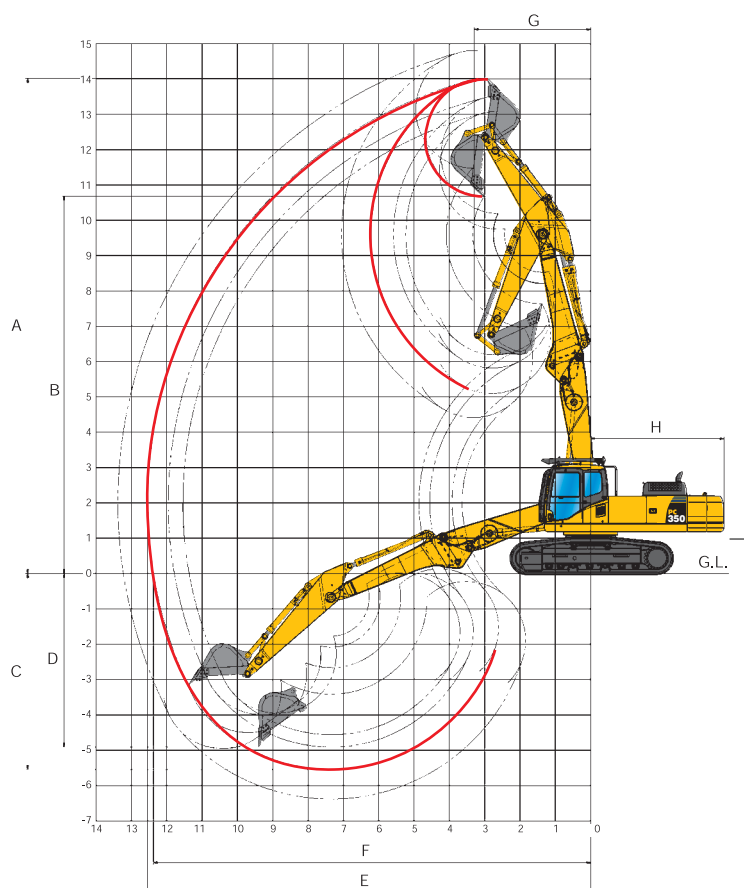

ARM LENGTH	2,6 m	3,2 m
A Max. digging height	13.520 mm	14.020 mm
B Max. dumping height	10.180 mm	10.680 mm
C Max. digging depth	4.915 mm	5.550 mm
D Max. vertical wall digging depth	4.295 mm	4.910 mm
E Max. digging reach	11.955 mm	12.540 mm
F Max. digging reach at ground level	11.780 mm	12.375 mm
G Min. swing radius (bucket loaded)	3.265 mm	3.295 mm
H Tail swing radius	3.820 mm	3.820 mm

Lifting Capacity

PC350LC-8

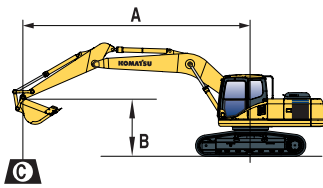

A – Reach from swing center

B – Bucket hook height

C – Lifting capacities, including bucket, bucket linkage and cylinder

– Rating over front

– Rating over side

– Rating at maximum reach

When removing bucket, linkage or cylinder, lifting capacities can be increased by their respective weights.

EXCAVATION BOOM - BENT POSITION

Arm length	A				9,0 m		7,5 m		6,0 m		4,5 m		1,5 m	
	B													
 2,6 m 1,014 kg 1,38 m ³	9,0 m	kg	7.150*	7.150*										
	7,5 m	kg	6.800*	6.400			8.900*	7.150						
	6,0 m	kg	6.750*	5.150			10.250*	7.000	11.700*	10.350				
	4,5 m	kg	6.950*	4.450	7.650	4.800	10.500	6.700	13.200*	9.600	17.400*	15.000		
	3,0 m	kg	6.600	4.050	7.450	4.600	10.050	6.250	14.300	8.750	17.200*	13.050		
	1,5 m	kg	6.400	3.900	7.250	4.400	9.600	5.850	13.550	8.050	11.450*	11.450*		
	0,0 m	kg	6.500	3.900	7.050	4.250	9.300	5.600	13.050	7.650	14.200*	11.550		
	-1,5 m	kg	6.950	4.150	7.000	4.150	9.150	5.450	12.850	7.500	18.050*	11.550	10.450*	10.450*
	-3,0 m	kg	8.000	4.800			9.150	5.450	12.900	7.550	15.950*	11.750	15.950*	15.950*
	-4,5 m	kg							11.300*	7.800	14.100*	12.150		
 3,2 m 1,014 kg 1,38 m ³	9,0 m	kg	4.950*	4.950*										
	7,5 m	kg	4.750*	4.750*			7.700*	7.350						
	6,0 m	kg	4.750*	4.600	6.400	5.000	9.500*	7.150						
	4,5 m	kg	4.900*	4.000	7.700	4.850	10.300*	6.750	12.200*	9.850	15.750*	15.750	24.300*	24.300*
	3,0 m	kg	5.200*	3.650	7.450	4.600	10.150	6.300	13.900*	9.000	17.350*	13.800		
	1,5 m	kg	5.750*	3.500	7.200	4.350	9.650	5.900	13.700	8.200	17.400*	12.300		
	0,0 m	kg	5.900	3.500	7.000	4.150	9.250	5.550	13.100	7.650	16.300*	10.450		
	-1,5 m	kg	6.250	3.650	6.850	4.050	9.050	5.350	12.800	7.400	17.750*	10.250	10.600*	10.600*
	-3,0 m	kg												
	-4,5 m	kg												

EXCAVATION BOOM - STRAIGHT POSITION

Arm length	A				10,5 m		9,0 m		7,5 m		6,0 m		4,5 m	
	B													
 2,6 m 1,014 kg 1,38 m ³	9,0 m	kg	7.650*	5.650					10.350*	6.800	10.750*	10.300	9.850*	9.850*
	7,5 m	kg	7.050*	4.400			7.550	4.700	10.650	6.800	10.850*	10.100	9.700*	9.700*
	6,0 m	kg	6.150	3.700			7.500	4.650	10.350	6.500	13.900*	9.500	16.750*	15.200
	4,5 m	kg	5.550	3.300			7.300	4.500	9.900	6.100	14.200	8.650		
	3,0 m	kg	5.300	3.100	5.500	3.250	7.100	4.250	9.450	5.700	13.300	7.850		
	1,5 m	kg	5.200	3.050	5.400	3.150	6.900	4.100	9.050	5.350	12.650	7.300		
	0,0 m	kg	5.350	3.100	5.400	3.150	6.750	3.950	8.850	5.200	12.450	7.100		
	-1,5 m	kg	5.650*	3.350			6.750	3.950	8.800	5.150	12.050*	7.100		
	-3,0 m	kg					5.650*	4.050	7.850*	5.250	9.150*	7.300		
	-4,5 m	kg												
 3,2 m 1,014 kg 1,38 m ³	9,0 m	kg	5.250*	4.750					8.300*	6.950	8.200*	8.200*	7.300*	7.300*
	7,5 m	kg	4.900*	3.800			7.650	4.800	8.700*	6.900	8.300*	8.300*	9.950*	9.950*
	6,0 m	kg	4.750*	3.200	5.600	3.350	7.550	4.700	9.950*	6.600	10.100*	9.700		
	4,5 m	kg	4.700*	2.900	5.550	3.300	7.350	4.500	10.000	6.200	14.500	8.900		
	3,0 m	kg	4.750	2.700	5.450	3.200	7.050	4.250	9.500	5.750	13.550	8.050		
	1,5 m	kg	4.650	2.650	5.300	3.050	6.850	4.000	9.050	5.350	12.800	7.400		
	0,0 m	kg	4.750	2.700	5.250	3.000	6.650	3.850	8.800	5.100	12.400	7.050		
	-1,5 m	kg	5.050	2.900	5.250	3.000	6.600	3.800	8.650	5.000	12.300	6.950	9.100*	9.100*
	-3,0 m	kg					6.650	3.850	8.700	5.050	10.500*	7.050		
	-4,5 m	kg												

Lifting capacity table is published for guidance only, the machine is not intended for use as a crane.

Lifting capacities are stated in kg, on the tip of the arm, for machine on firm, level supporting surface.

The weight of any attachment used should be deducted from the values shown, to calculate payload.

Indicated loads are based on ISO 10567 standard and do not exceed 75% of tipping or 87% of hydraulic capacity (indicated by *).

Lifting capacity of the machine is limited by machine stability, hydraulic capacity and maximum permissible load of the attachment.

Standard and Optional Equipment

ENGINE

Komatsu SAA6D114E-3, 194 kW turbocharged common rail direct injection diesel engine	●
EU Stage IIIA compliant	
Suction type cooling fan with radiator fly screen	●
Automatic engine warm-up system	●
Engine overheat prevention system	●
Fuel control dial	●
Auto-deceleration function	●
Engine key stop	●
Engine ignition can be password secured on request	●
Alternator 24 V/60 A	●
Starter motor 24 V/11 kW	●
Batteries 2 × 12 V/140 Ah	●

HYDRAULIC SYSTEM

Electronic closed-centre load sensing (E-CLSS) hydraulic system (HydrauMind)	●
Pump and engine mutual control (PEMC) system	●
5-working mode selection system; power mode, economy mode, breaker mode, attachment mode and lifting mode	●
PowerMax function	●
Adjustable PPC wrist control levers for arm, boom, bucket and swing, with sliding proportional control for attachments and 3 auxiliary buttons	●
In-line filter for hydraulics	●
Two additional service valves (full flow)	●
One additional service valve (1/2 flow)	●
Drain circuit for hydraulic attachment rotation motors	●

UNDERCARRIAGE

Track roller guards	●
Track frame under-guards	●
LC, NLC or hydraulic adjustable wide gauge (HWG) undercarriage	○
600, 700 mm triple grouser track shoes (HWG: 700 mm only)	○
Full length track roller guards (not HWG)	○

SERVICE AND MAINTENANCE

Automatic fuel line de-aeration	●
Double element type air cleaner with dust indicator and auto dust evacuator	●
KOMTRAX™ - Komatsu satellite monitoring system	●
Multi-function video compatible colour monitor with Equipment Management and Monitoring System (EMMS) and efficiency guidance	●
Toolkit and spare parts for first service	●
Service points	○

CABIN

Demolition Safety SpaceCab™, with ISO 10262 level 2 FOPS guards and roof screen wash/wiper, safety glass windows, pull-up type front window with locking device, fixed roof window with wiper and washer, removable lower window, front window wiper	●
Tilting cab, with control equipment, hydraulic power hoses and cab raise cylinders	●
Heated air suspension seat with lumbar support, height adjustable arm rests and retractable seat belt	●
Automatic climate control system	●
12 Volt power supply	●
Beverage holder and magazine rack	●
Hot and cool box	●
Radio	●

WORK EQUIPMENT

Demolition first boom: Includes demolition first boom, fitted with hydraulic pipework, with quick connectors, suitable for operation of high reach demolition work equipment and operation of rotating crusher attachment	●
Two-mode boom control	●
Excavation arm assemblies: Includes bucket cylinder and piping, bucket linkage, 2,6 m or 3,2 m standard arm, with 2 additional dual flow proportional service circuits, with drain circuit for hydraulic attachment rotation motors	○
Excavation boom: Includes two position excavation boom (bent/straight) to fit onto demolition first boom. Associated pipework for excavation arm cylinder and bucket cylinder. Quick connectors to suit demolition first boom. With pipework suitable for operation of excavation equipment and rotating crusher attachment (includes pipework associated with excavation boom)	○
Demolition second boom: Includes demolition extension boom (2,7 m) fitted with hydraulic pipework, with quick connectors, suitable for operation of high reach demolition work equipment and operation of rotating crusher attachment	○
Demolition third boom: Includes demolition third boom, mid link, high reach demolition arm, demolition attachment linkage. Fitted with hydraulic pipework, with quick connectors, suitable for operation of high reach demolition work equipment and operation of rotating crusher attachment	○
Komatsu buckets	○

SAFETY EQUIPMENT

Rear view camera system	●
Electric horn	●
Overload warning device	●
Lockable fuel cap and covers	●
Audible travel alarm	●
Boom safety valves	●
Large handrails, r.h. rear-view mirror	●
Battery main switch	●

DRIVES AND BRAKES

Hydrostatic, 3-speed travel system with automatic shift and planetary gear type final drives, and hydraulic travel and parking brakes	●
PPC control levers and pedals for steering and travel	●
PPC pedal for high reach demolition mid link	●

LIGHTING SYSTEM

Working lights: 2 revolving frame lights and 1 boom light, 4 cab roof (front) lights, 1 cab roof (rear) light, 1 counterweight (rear) light	●
---	---

OTHER EQUIPMENT

Heavy duty revolving frame with heavy duty demolition under covers and side guard protection	●
Counterweight prepared for demolition counterweight	●
Remote greasing for swing circle and pins	●
Electric refuelling pump with automatic shut off function	●
Standard colour scheme and decals	●
Parts book and operator manual	●
Additional counterweight. To fit into main demolition counterweight when high reach demolition equipment is installed. Removable for excavation operations. Included with any high reach boom equipment	○
Biodegradable oil for hydraulic system	○
Customised paint	○

Further equipment on request

- standard equipment
- optional equipment

Hydraulic Excavator

PC350LC/NLC-8

High Reach Demolition Specification

Your Komatsu partner:

KOMATSU

**Komatsu Europe
International NV**

Mechelsesteenweg 586
B-1800 VILVOORDE (BELGIUM)
Tel. +32-2-255 24 11
Fax +32-2-252 19 81
www.komatsu.eu

UESS13403 09/2010

Materials and specifications are subject to change without notice.
KOMATSU is a trademark of Komatsu Ltd. Japan.